

Ultrasonic sensor **UR18-CM1** series

Feature Description

- ◆ M18 threaded sleeve for easy installation
- ◆ 1 NPN or PNP switch output
- ◆ Analog voltage output 0-5/10V or analog current output 4-20mA
- ◆ Digital TTL output
- ◆ Output can be changed through serial port upgrade
- ◆ Setting detection distance through teach-in lines
- ◆ Temperature compensation

Model specifications

NPN	NO/NC	UR18-CM1DNB-E2	PNP	NO/NC	UR18-CM1DPB-E2
NPN	Hysteresis mode	UR18-CM1DNH-E2	PNP	Hysteresis mode	UR18-CM1DPH-E2
0-5V	Analog output	UR18-CM1DU5-E2	4-20mA	Analog output	UR18-CM1DI-E2
0-10V	Analog output	UR18-CM1DU10-E2	Com	TTL232	UR18-CM1DT-E2

Specifications

Sensing range	60-1000mm	Output indication	Red LED: No target detected in teach-in state, always on
Blind area	0-60mm		Yellow LED: In normal working mode, the switch status
Resolution ratio	0.5mm		Blue LED: Target detected in teach-in state, flashing
Repeat accuracy	±0.15% of full scale value		Green LED: Power indicator light, always on
Absolute accuracy	±1% (temperature drift compensation)	Input type	With teach-in function
Response time	100ms	Ambient temperature	-25°C...70°C(248-343K)
Switch hysteresis	2mm	Storage temperature	-40°C...85°C(233-358K)
Switching frequency	10Hz	Output characteristics	Support serial port upgrade and change the output type
Power on delay	<500ms	Material	Copper nickel plating, glass bead filled epoxy resin
Working voltage	15...30VDC	Protection degree	IP67
No-load current	≤25mA	Connection	4 pin M12 connector

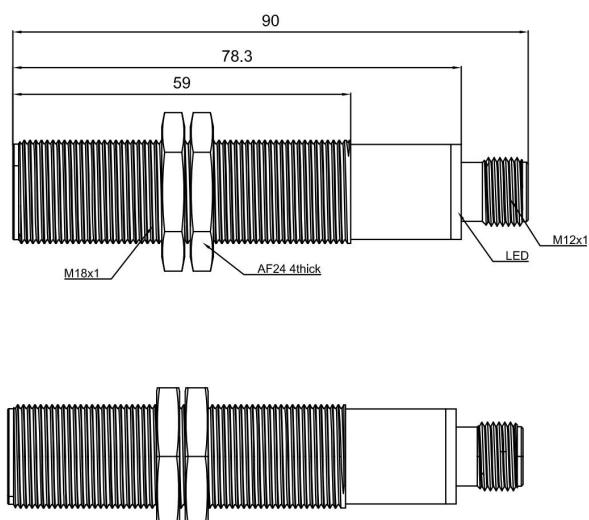
Dimension

Wiring diagram
